

ADP2100 Manual

Digital Differential Pressure Sensor

- Excellent repeatability , no drift
- Built-in temperature compensation
- High reliability and long-term stability
- high signal to noise ratio
- Built-in MCU with high processing capability
- Short response time and fast measurement speed
- Small size and light weight

Product summary

The ADP2100 sensor is a digital differential pressure sensor, and its internal thermal sensor element measures the pressure difference of the gas. The sensor can measure the pressure difference of air, nitrogen, and oxygen without drift and with high precision. It also has excellent accuracy at low pressure difference. It has good performance in sensitivity, shock resistance and temperature change.

The ADP2100 sensor has standard I2C interface, simple communication mode, and can be easily connected to the microprocessor.

Application range

The ADP2100 is designed for high-accuracy measurement of differential pressure with a fast response time of 10 ms and can respond quickly to air, nitrogen, and oxygen. It can adapt to HVAC applications with harsh environment and low cost requirements, such as: VAV controller, burner, heat recovery system and filter monitoring); it can also be customized and used in specific scenarios according to customer needs, such as: fire protection in smart fire protection Residual pressure monitoring system; pipe blockage monitoring and variable air volume control in electrical equipment such as heating air conditioners and fresh air systems, building automation, precise control and monitoring of gas flow in the medical field, etc.



Figure 1. ADP2100 Differential Pressure Sensor

1. Sensor parameters and materials

1.1 Sensor parameters

Table 1. Sensor parameters

Parameter	Describe
Measuring range	-500 ~ 500Pa
Zero point accuracy	0.3Pa
Precision	Reading × 3%
Zero-point repeatability	0.1Pa
Repeatability	Reading × 0.5%
Year offset	< 0.05Pa
Response time	10ms
Calibration gas	Air
Fluid compatibility	Air, nitrogen, oxygen (non-condensing state)
Temperature Compensation Range	0 ~ 50°C
Shell material	LCP

Note: Unless otherwise stated, all sensor differential pressure parameters are measured at 25°C , VDD = 3.3 V, and absolute pressure = 966 mbar .

1.2 Temperature parameters

Table 2. Temperature Parameters

Parameter	Value
Measuring range	-40 ~ 85°C
accuracy	From -10 to60°C at 2°C at -40~85°C at 3°C
repeatability	0.3°C

Note: The temperature indicated in the table is the temperature inside the sensor . This temperature value depends not only on the gas temperature, but also on the ambient temperature around the sensor.

1.3 Electrical parameters

Table 3. Electrical Parameters

Parameter	Symbol	State	Min	Typ	Max	unit
voltage	V _{DD}	-	3.2	3.3	3.4	V
supply current	I _{DD}	Measurement	-	3.8	5.5	mA
		idle state	-	-	1.1	mA

1.4 Timing parameters

Table 4. Timing Parameters

Parameter	Describe
Power-up time (time for sensor to be ready)	≤ 25ms _
I ² C SCL Frequency	≤ 100kHz _
Update rate of differential pressure value (in continuous mode)	100Hz _

1.5 Mechanical parameters

Table 5. Mechanical Parameters

Parameter	Value
Overpressure allowed	1 bar
Rated Burst Pressure	5 bars
weight	0.4g _

1.6 Absolute Minimum and Maximum Ratings

Table 6. Absolute Minimum and Maximum Ratings

Parameter	Scope
Voltage	-0.3 ~ 3.4V
The maximum voltage on pins (SDA , SCL)	-0.3 ~ V _{DD} +0.3 V
Input current on any pin	± 70mA
Working and storage temperature range	-40 ~ 85°C
storage temperature range	-40 ~ 85°C
ESD HBM (Human Body Model)	2kV _

Note: This parameter is for air and nitrogen. Prolonged exposure to oxygen at elevated temperatures (> 50 °C) will shorten product life . V_{DD} in the table refers to the power supply voltage V_{DD} in Table 3.

2. Pin assignment

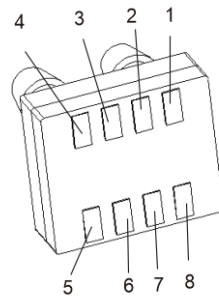

Figure 2. ADP2100 Digital Pinouts

Table 8. ADP2100 Digital Pin Assignments

Pin	Name	Describe
1	VDD	VDD power supply
2	SDA	Serial data (I ² C interface)
3	GND	grounding
4	SCL	Serial Clock (I ² C Interface)
5~8	N/ C	empty pin

3. I²C and CRC check

I²C address of ADP2100 is 0x 25 , namely 0 100101 , a total of 7 bits. The address is followed by a read or write bit, the I²C address followed by a write bit command is 0x 4 a , followed by a read bit command is 0x 4 b . CRC (Cyclic Redundancy Check) is an algorithm that performs polynomial operations on data and appends the result to the end of the frame. The receiving device also executes a similar algorithm when receiving data, which is mainly used to detect or verify possible errors after data transmission or storage to ensure the correctness and integrity of data transmission.

3.1 I²C timing

2 and Figure 3 show the timing of I²C host (computer) writing data and receiving instructions and data and the instructions in the figure are all 16bit. The sensor data is output with 16bit, and each word is followed by an 8bit checksum to ensure the reliability of communication.

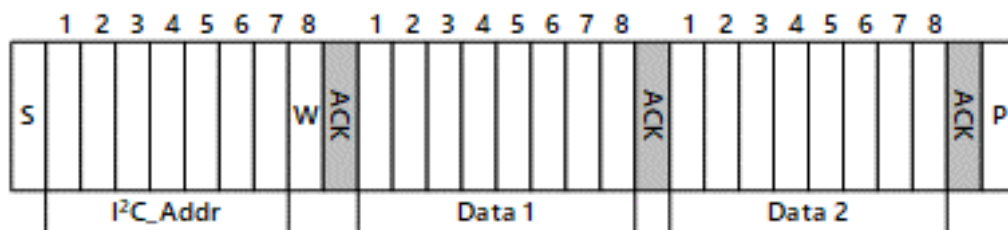
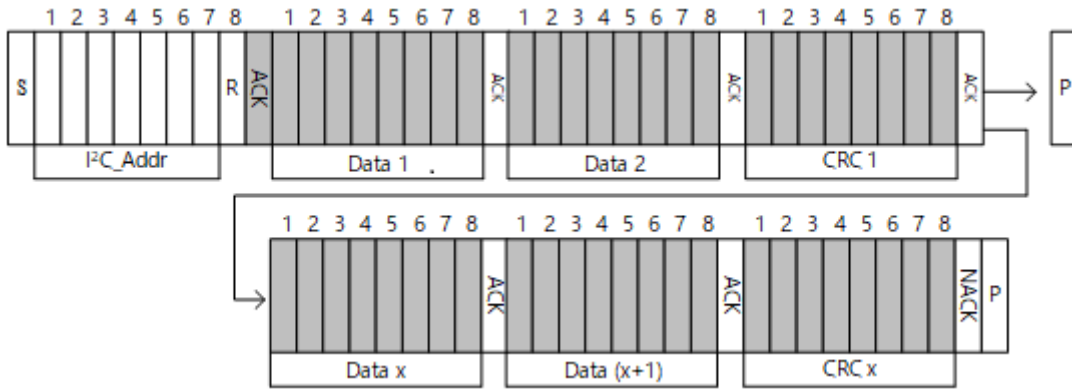

Figure 2. I²C master executes the timing diagram of writing 16 -bit data instruction



S: start bit (Start); W/R: write/read bit; ACK: acknowledge bit; NACK: non-acknowledge bit; P: stop bit (Stop); Data x: data command; CRC x: verification command; white bottom data bit: master signal; gray bottom data bit: slave signal

Figure 3. I²C master executes the read command and receives multiple 16-bit data commands and CRC check code timing diagram

3.2 I²C read command

The sensor can measure differential pressure and temperature at the same time, and the above two measurement results can be read through the hexadecimal I²C read command, continuous measurement command (0x 361 E) and single measurement command (0x 372 D) , During continuous measurement, the update time of the measurement result is 10ms .

Sending the continuous measurement command, the chip will continue to measure and update the measurement results. New results can be continuously read using only the continuous measurement command. In addition, product identification and communication testing can also be performed through the product type read command (0xE 201). See Table 9 for continuous measurement and product type read instruction information.

Table 9. I²C Read Commands and Their Descriptions

Instruction	Byte description	Remark
Continuous measurement (0x 361 E)	Byte 1: high 8 bits of differential pressure raw data Byte 2: low 8 bits of differential pressure raw data Byte 3: CRC Byte 4: high 8 bits of temperature data Byte 5: low 8 bits of temperature data Byte 6: CRC	After starting continuous measurement, the measurement result can be read out; the temperature and scale factor do not need to be read out every time; Read operations can be terminated by NACK and STOP conditions.
Product type read (0xE 201)	Byte 1: data high 8 bits (41) Byte 2: data low 8 bits (5 3) Byte 3: CRC (D 1)	The product type is a unique identifier, and the product type reading instructions read by the same type of sensor are consistent. The product type code for the ADP2100 is 0x 4153 .

3.3 Checksum calculation

CRC generally has three standards: CRC 8 , CRC 16 , and CRC 32 , and CRC 8 is used in ADP2100 . Taking the polynomial $x^8 + x^5 + x^4 + 1$ (0x31) as an example, the CRC 8 checksum byte is generated by the CRC algorithm with the properties shown in Table 1.0 .

Table 1 0. Values corresponding to each attribute

Attributes	Value
length	8bit
polynomial	$x^8 + x^5 + x^4 + 1$
initial value	0xFF
Whether the input needs to be reversed	False
Whether the output needs to be inverted	False
Final XOR value	0x00

Calculating the CRC code is as follows:

```

//*****
// Function name: Calc_CRC8
// Function: CRC8 calculation, initial value: 0xFF, polynomial: 0x31(x8 + x5 + x4 + 1)
// Parameter: u8 *data: the first number of CRC validation; u8 Num: indicates the length of CRC verification data
// Returns: crc: The calculated value of crc8
//*****
u8 Calc_CRC8(u8 *data, u8 Num)
{
    u8 bit,byte,crc=0xFF;
    for(byte=0; byte<Num; byte++)
    {
        crc^=(data[byte]);
        for(bit=8;bit>0;--bit)
        {
            if(crc&0x80) crc=(crc<<1)^0x31;
            else crc=(crc<<1);
        }
    }
    return crc;
}
    
```

4. Signal conversion to physical value

Differential pressure and temperature signals to physical values is done through scaling factors.

4.1 Scale factor

Table 1 1. Scale factor

Parameter	Describe
Differential pressure scaling factor	60Pa ⁻¹
Differential pressure scaling factor	14 ' 945 (inch H ₂ O) ⁻¹
Temperature scaling factor	200°C ⁻¹

4.2 Differential pressure

Calibrated differential pressure signal read from the sensor is a signed integer (two's complement). An integer value can be converted to a physical value by dividing it by a scaling factor.

Pressure difference = sensor output integer value ÷ pressure difference scaling factor

The number read from ADP 2100 is 0x 1770, and 0x 1770 is converted into a decimal integer to 6000, and the pressure difference = 6000 ÷ 60 = 100 Pa.

4.3 Temperature

Signal read from the sensor is a signed integer (two's complement). An integer value can be converted to a physical value by dividing it by a scaling factor.

Temperature (°C) = sensor output integer value ÷ temperature scaling factor

For example, the number read from the sensor is 0x 0 FA 0 , 0x0FA0 converted into a decimal integer is 4 000 , temperature = 4000 ÷ 200 = 20 °C .

5. Dimensions

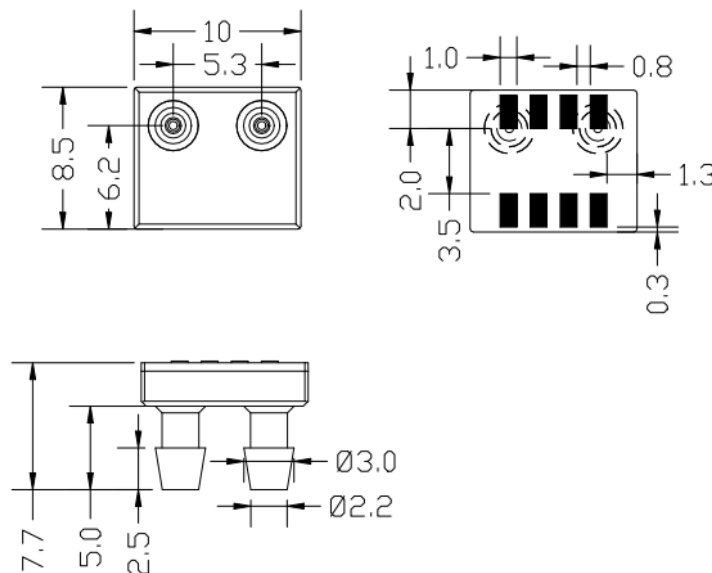

Figure 4. ADP2100 (unit: mm, tolerance: ±0.1 mm)

WARNINGS AND PERSONAL INJURY

Do not use this product in safety protection devices or emergency stop equipment, and in any other application where failure of the product may cause personal injury, unless there is a specific purpose or authorization for use. Refer to the product data sheet and instruction manual before installing, handling, using or maintaining this product. Failure to follow recommendations could result in death or serious personal injury. The company will not be responsible for all compensation for personal injury and death arising therefrom, and exempt any claims that may arise from the company's managers and employees, affiliated agents, distributors, etc., including: various costs, claims fees, attorney fees, etc.

Quality Assurance

Guangzhou Aosong Electronics Co., Ltd. provides the direct purchasers of its products with the quality assurance in the following table (calculated from the date of delivery), and indicates the technical specifications in the Aosong Electronics product manual. If the product is proven to be defective within the warranty period, the company will provide free repair or replacement services.

Warranty Description

Product Category	Warranty period
ADP2100 Differential Pressure Sensor	12 months

The company is only responsible for the products that are defective due to the application in the occasions that meet the technical conditions of the product. The company does not make any guarantees for product applications in special scenarios that are not recommended. The company also does not make any commitment to the reliability of the product applied to other non-company supporting products or circuits.

This manual is subject to change without notice.

The final interpretation right of this product belongs to Guangzhou Aosong Electronics Co., Ltd.

Copyright © 2022, ASAIR®